



Café Racer



SANREMO
COFFEE MACHINES

Born to run

*The maximum result in the cup,
one coffee after another*



SANREMO

COFFEE MACHINES

Take a ride,
explore its essence



ENERGY SAVING SYSTEM

Insulation and energy saving system up until 40% compared to single boiler machines



VOLUMETRIC PUMP PERFORMANCE

The unique 79.3 US gal - 300 l/h pump guarantees constant pressure in all conditions of machine use



HIGH RESOLUTION PERFORMANCE

For an accurate and precise coffee dose in the cup



POWER DRY STEAM

Low additional liquid during the milk steaming



EASY SERVICE

Fast access to the internal parts for quick and easy technical service



SOFT PRE-INFUSION

Flowactive System: for precise control of the water flow and pre-infusion time



EVERYTHING UNDER CONTROL

System digital display to provide visibility of all working parameters

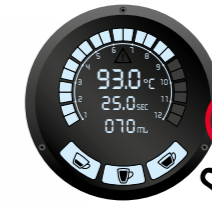

Smart-touch setting of the individual groups

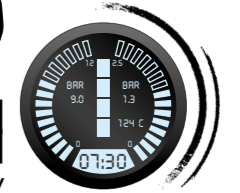

HEART OF STEEL

For maximum thermal stability:

- Groups in AISI 316L, weight 17.6 lb / 8 kg each
- Portafilters AISI 316
- Boilers AISI 316



ADJUSTABLE HEIGHT WORK SURFACE

Innovative Sanremo "All in one" suspension system that allows cups of different shapes and heights (adjustable from 3.35 to 5.90 inches / from 85 to 150 mm)



Characteristics



AISI 316L STEEL GROUPS WITH 17.6 lb / 8 kg PURE STEEL
Exclusive Sanremo design ensure exceptional thermal stability and maximum resistance to oxidation and lime scale.



AISI 316 STAINLESS STEEL PORTAFILTER WITH "COMPETITION FILTER"
Exclusive Sanremo design, with shape and volume designed to capture the best coffee aromas and fragrances.



AISI 316L STAINLESS STEEL FREE MOTION STEAM TAPS
Flexible control system for producing and dispensing steam.



AISI 316L STAINLESS STEEL STEAM WAND "COLD TOUCH"
Anti-burning feature even in conditions of prolonged use, fitted with "Latte Art" high-performance steam terminals.



PROGRAMMABLE ELECTRONIC PRE-INFUSION
Allows control with 0.1 second tolerance of the flow of water that wets the coffee bed, with programming of 4 different profiles for each group.



INDEPENDENT ADJUSTMENT OF THE PID INFUSION WATER TEMPERATURE
Precision setting (gradient ± 0.5 °C with measured constancy lower than 0.2°C).



SYSTEM DISPLAY
Visibility of all the machine functions: temperatures, pressures and levels.



COFFEE UNIT SINGLE DISPLAY
Control of all coffee extraction parameters.



MIXED INFUSION HOT WATER FOR TEA AND HERBAL TEAS
Instantaneous mixing of fresh water and steam for a better chemical and organoleptic quality.



HIGH PERFORMANCE VOLUMETRIC PUMP 79.3 US gal - 300 l/h ***
Pressure stability also with prolonged and contemporary use of more than one group.



HIGH PERFORMANCE FLOWMETERS
For an accurate and precise coffee dose in the cup.



STEAM CONTROL ADJUSTABLE ELECTRONIC PRESSURE SWITCH
Sensor with 0.02 bar precision that allows the chosen pressure and steam in the boiler to be kept constant in all conditions of use.



PROGRAMMABLE CUP WARMER TEMPERATURE
Allows the cups to be kept at the optimum temperature in the most different climatic conditions.



ELECTRONIC AUTO-LEVEL
Through an electronic level probe the boiler is automatically filled and maintained to the right filling level.



LED LIGHTING OF THE WORK AREA
Allows efficient working in any condition of environmental lighting.



AUTO-DIAGNOSIS, STATISTICAL DATA, SCHEDULED MAINTENANCE
Maintenance can be scheduled according to litres or number of coffees dispensed.



AUTO-ON, AUTO-OFF AND DAY-OFF FUNCTION
Programmable on-off timer for each day and/or daily timetables.



AUTOMATIC CLEANING CYCLE
Process for coffee groups cleaning.



BOILER WATER REGENERATION
Ensures resetting of the optimum chemical characteristics of the water and correct mineralisation.



GROUP FLUSHING
With a simple pressure of the button a small quantity of water is dispensed to allow the group to be always clean.

Optional



STAINLESS STEEL NAKED PORTAFILTERS



HIGH POWER STEAMER TERMINAL
(bigger holes diameter)



EXTERNAL VOLUMETRIC PUMP

Café Racer

Versions

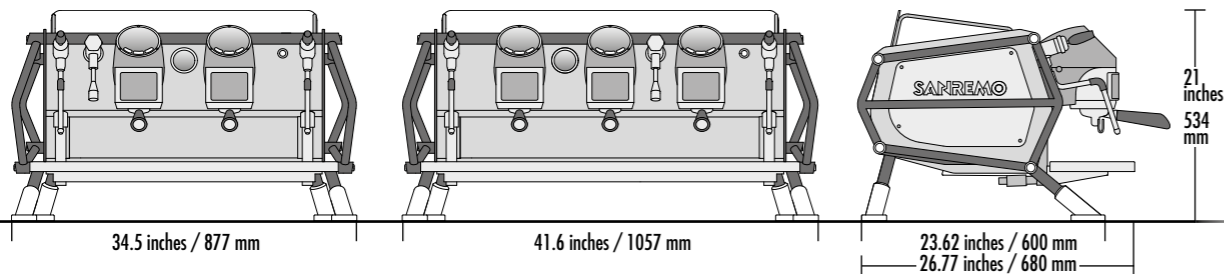

- 2 group CR**
- _____ 2 steam taps
 - _____ 1 water tap
 - _____ 1 one-cup portafilters
 - _____ 2 two-cup portafilters

- 3 group CR**
- _____ 2 steam taps
 - _____ 1 water tap
 - _____ 1 one-cup portafilters
 - _____ 3 two-cup portafilters



MULTIBOILER SYSTEM

Sanremo Café Racer multiboiler system ensures a new level of thermal precision thanks to the 4 points of temperature PID control.

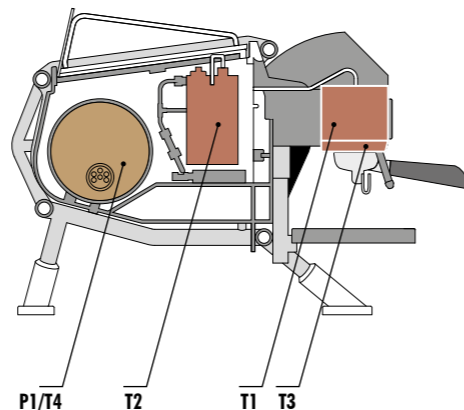

Technical data		2 group	3 group
voltage	V	220-240 1N / 380-415 3N	
power input	kW	7.03	8.35
steam boiler capacity	US gal / lt	2.11 / 8	2.64 / 10
services boiler resistance power	kW	3.85	3.85
external pump power	kW	0.165	0.165
preheating boiler capacity	US gal / lt	0.264 / 1.0	0.396 / 1.5
preheating boiler resistance power	kW	1.0	1.5
cup-heater power	kW	0.16	0.2
units boiler capacity	US gal / lt	0.264 / 1.0	0.396 / 1.5
units boiler resistance power	kW	1.6	2.4
net weight	lb / kg	214 / 97	265 / 120
gross weight (with shipping crate)	lb / kg	267 / 148	377 / 171



NAKED

Choose your style,
dress up your Café Racer

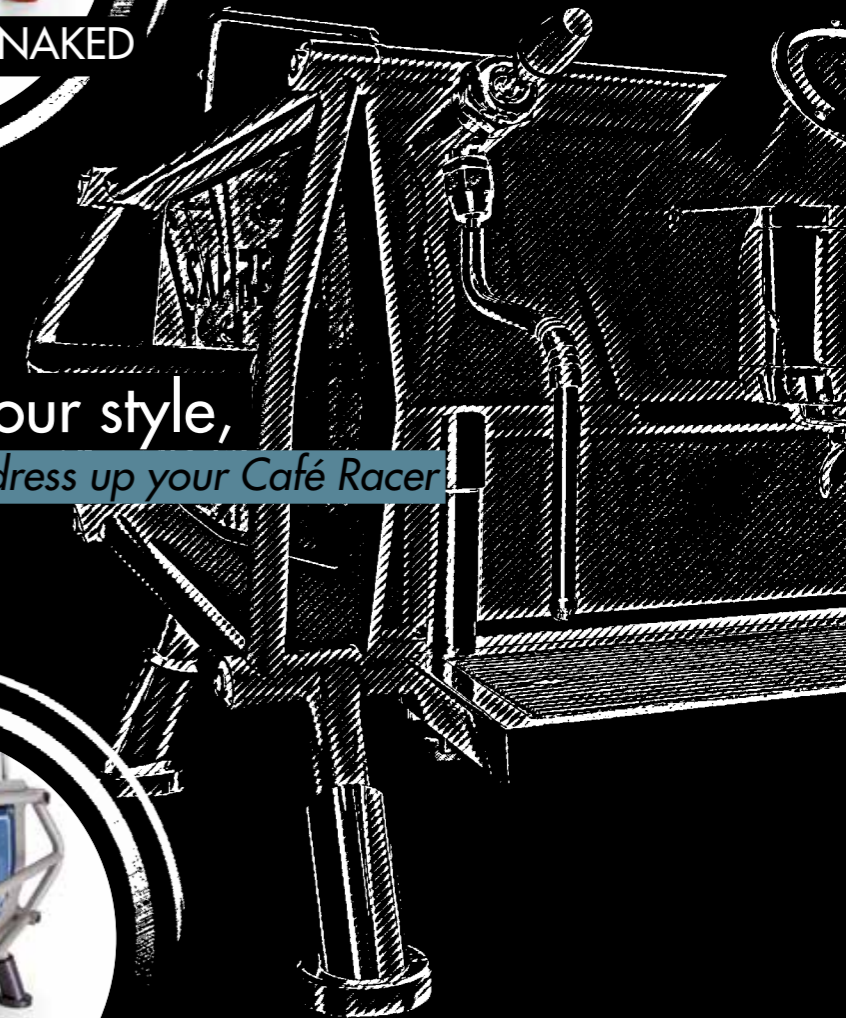

FREEDOM



CUSTOM



Built for free spirits

Sometimes designs come to be to achieve a precise objective; other times to make a dream come true; or to follow an ambition.

But this is our story of a coffee machine conceived in absolute freedom. No hurry, no restraints, no obligations: except to guarantee impeccable performance to baristas all over the world.

Hence the precise and accurate intuition: to enclose the best of Sanremo technology in a sturdy and stylish chassis: like a motorcycle chassis of the legendary café racer.



From the idea, to the design, to the Sanremo R&D team, to SWAT (*Sanremo World Academy Team*): the project has gone around the world a couple of times. It has been shared with the best operators in the industry and it has become a reality. Café Racer by Sanremo is a powerful and reliable machine, easy-to-handle, versatile and stylish.

A unique, high performance coffee machine, ready to be desired by all coffee professionals.





NAKED
look into the soul



With its unmistakable transparent sides, the **Naked Café Racer** allows you to see its powerful heart of pure stainless steel.

The chassis is a sturdy frame with a functional design, supporting and enhancing the essence of the coffee machine.

The **Naked Café Racer** is available in 2 finishes: black and steel. Both available with some components in black or red.

* rings, bolts, feets, boiler insulation

✓ **Naked Black** 
Black 

✓ **Naked Black** 
Red 



✓ **Naked Steel** 
Black 

✓ **Naked Steel** 
Red 





✓ **Freedom Black** 
Black | P1|P2|P3|P4 



✓ **Freedom Steel** 
Black | P1|P2|P3|P4 



FREEDOM
option to fit any character



The Freedom Café Racer has 4 coloured side panels available that are enhanced with the rear-lit logo. The classic logo design is inspired by *café racer* motorcycles. A tradition rich in stories, emanating character, style and personality.

The machines are available in versions with a black or steel chassis,  
plus an exclusive red finish on some components* . ● ●

* rings, bolts, feet



✓ **Freedom Black** 
Red | P4 

✓ **Freedom Steel** 
Red | P4 



_ CUSTOM

welcome free spirits



Welcome to the Custom world, greatest potential expression of the entire project named "Cafè Racer": customization and uninterrupted evolution. Some versions have already become real icons. Choose your style and get on your exclusive Cafè Racer.



_ Renegade

Manually oxidised copper, reddish brown brass and pure hand-sewn natural leather: the **Renegade Café Racer** exudes originality and a strong character in each and every feature.

The lateral pockets, in natural leather as well, are an optional for those who are looking for a further characterisation: with a resealable flap or with different glove boxes.

- handmade finishes [
-  **Dark green**
 -  **Oxidized copper**
 -  **Brown leather**
 -  Polished brass
 -  Oxidized brass







_ CUSTOM



_ Dolomiti

A totally black edition designed for the most exclusive locations: black satin stainless steel, naturally dyed leather and dark chrome finishing. Pure essentiality of materials and design, for a version of incomparable elegance.

- hand-sewn
-  **Matt black**
 -  **Black steel**
 -  **Black leather**
 -  Dark chrome
 -  Stainless steel





_ CUSTOM



_ Moto di Ferro

Just out of the workshop, it has already become a legend: because this customization has actually been designed and built in a real garage of custom bikes from which it takes its name. To drive it, or rather to use it, is something for the few, destined to real rebellious spirits.

- **Matt black**
- **Satinized aluminum**
- **Stainless steel**
- **Black**



_ CUSTOM



_ Racing

At the first glance, the frame recalls speed, performance and winning character: the carbon finishing and the bright colours are designed for those who love to be on the track with a coffee machine designed to meet everyday challenges.

- **Gloss red**
- **Matt white**
- **Carbon**
- **Stainless steel**
- **Black**

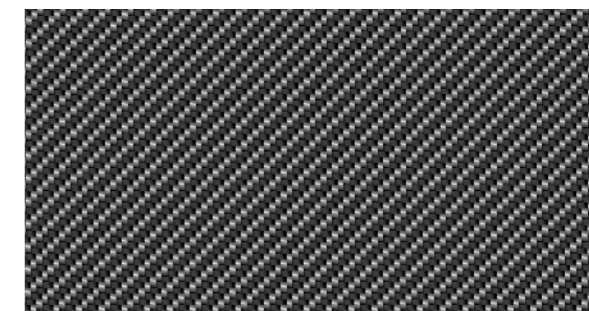

_ Black & White

_ CUSTOM

It's the most popular version: the elegance of white elements and the sophistication of black details combined together in a model that satisfies coffee shops trends.



- **Matt white**
- ○ **Stainless steel**
- **Matt black**
- **Matt white**

_ Full White

Pure white without any compromise as the drip tray. One of the most amazing version with the stronger identity ever.



_ White & Wood Standard

_ CUSTOM

Simple and clean, the natural oak matches the white dye with elegant naturalness.



- **Matt white**
- **Natural oak**
- ○ **Stainless steel**
- **Natural oak**
- optional* **Matt white tray**

_ White & Wood Slim

Without lateral frame, the White & Wood Slim version discreetly fits in spaces with a minimal design.

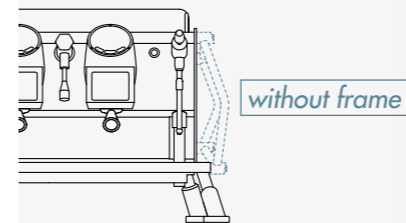

Pre-infusion made to measure

easily navigate the grouphead display

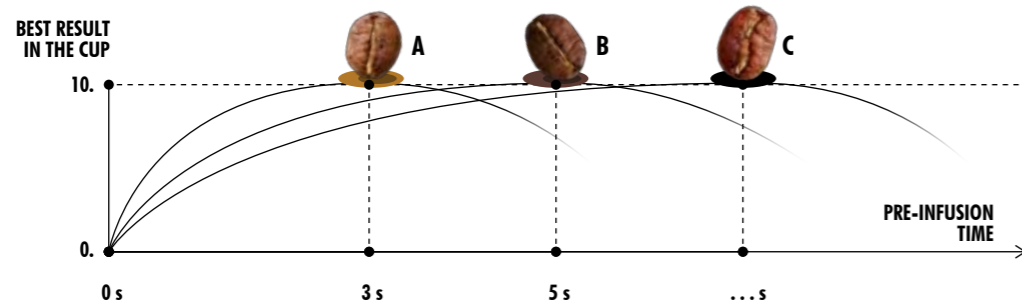

Examples of different coffee types:

- BLEND / A
- BLEND / B
- SINGLE ORIGIN / C

Every single origin or coffee blend has different requirements. For a perfect and homogeneous extraction of coffee solubles, it is fundamental to be able to control the elements of pre-infusion.

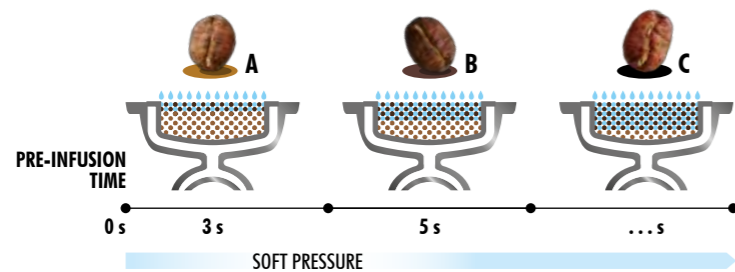

Pre-infusion is the first phase of espresso brewing. Its primary function is to saturate and prepare the coffee bed for optimal extraction. Pre-infusion also allows uniform delivery and aids in preventing channeling.

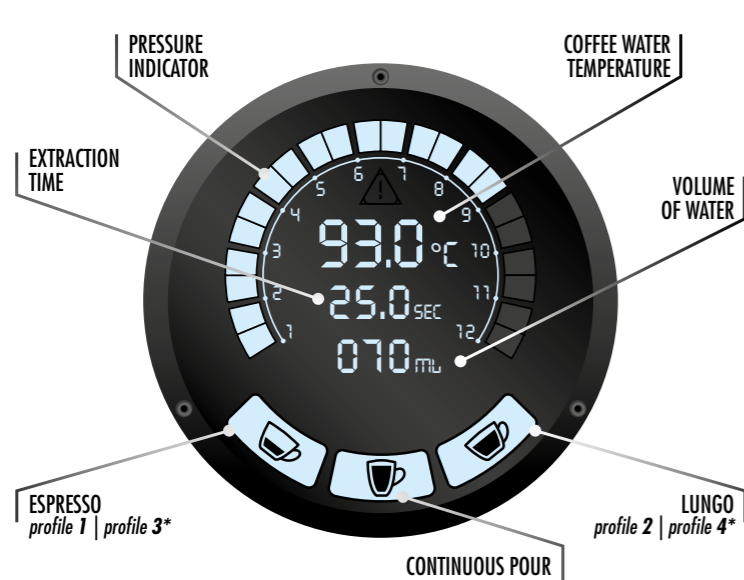

Through the display you can easily program each group for:

- pre-infusion time
- volume of water for extraction
- temperature

For each group you can save 4 different profiles, as well as the continuous dispensing function.

STANDARD SELECTION
> two profiles

* DOUBLE PRESS
> four profiles



STAND-BY



PRE-INFUSION



INFUSION

Everything under control

discover the functions of the digital system display

A look is all it takes: pressure, temperature and water levels are constantly monitored by high-precision electronic sensors, which immediately show real-time values and volumes with absolute reliability.

The display is also a handy programming interface for the maintenance technician.



The display allows the barista to:

- check and program the pressure, temperature and water levels
- collect statistics of the number of coffees, water dispensed, water consumed
- program days and times for switching on and off
- receive warnings for cleaning, washing and component malfunctions
- schedule maintenance
- carry out auto-diagnosis



Foam with an artist's touch

high-performance steam function



Use the best Sanremo technology, with impeccable performance, to give free rein to your creativity:

- dedicated steam boiler
- free motion steam taps
- cool-touch steam wand
- high capacity and fast recovery



REACH US

Mobile number: +966 53 885 9093

Website: www.rfa-sa.com , <https://sanremosaudiArabia.com/>

Online shop: <https://shop.rfa-sa.com/>

Email: customer-service@rfa-sa.com

Location: Al Thumama, Riyadh, Saudi Arabia

